

Pixelink[®]

AMETEK[®]

PL-D759

CMOS | SONY IMX255 | GLOBAL SHUTTER

The PL-D family of cameras links together the benefits of high frame rate CMOS technology with the high speed data throughput of USB 3.0 technology. The PL-D759 camera provides low noise images for outstanding value for a broad range of industrial applications.

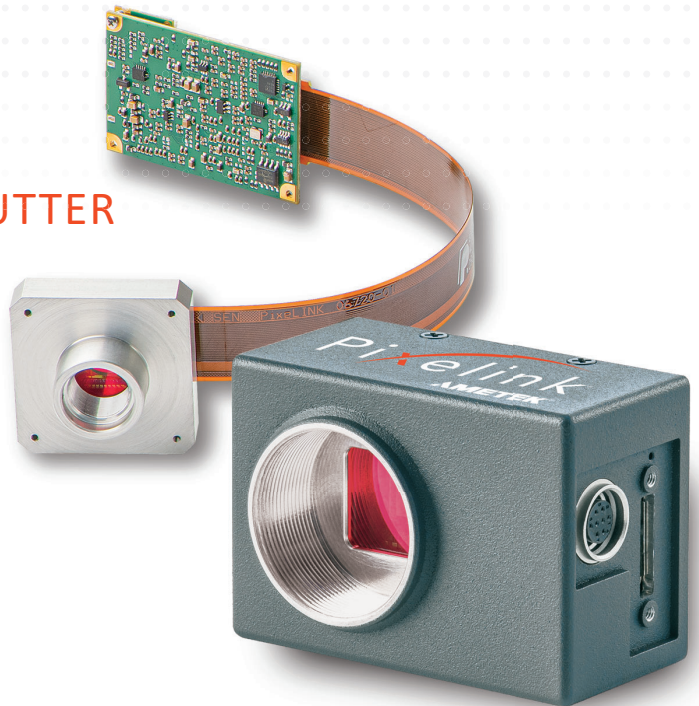

KEY FEATURES

9 MP
CMOS



45 fps



3.45 µm



16.1 mm



1"



12-BIT



COLOR



MONO



USB 3



TYPICAL APPLICATIONS

- Parts Inspection
- Medical Imaging
- Metrology
- Strength / Stress Testing
- PCB & Flat Panel Display Inspection
- Biometric

SENSOR	
Sensor	Sony IMX255
Type	CMOS Global Shutter
Resolution	8.85 MP (4096 x 2160)
Pixel Pitch	3.45 μm x 3.45 μm
Active Area	16.1 mm diagonal

PERFORMANCE SPECIFICATIONS	
FPN	<0.03% of signal
PRNU	<0.4% of signal
Dynamic Range	70 dB
Bit Depth	8-bit and 12-bit
Color Data Formats	Bayer 8, Bayer 12 Packed, Bayer 16 and YUV422
Mono Data Formats	Mono 8, Mono 12 Packed & Mono 16

FRAME RATES	
Resolution	Free Running
4096 x 2160	45.2 fps
1280 x 1024	98.4 fps
640 x 480	198.6 fps
* Frame rate will vary based on host system and configuration.	
** Above calculations based on fixed frame rate mode.	

INTERFACES	
Interface Data Rate	USB 3.0 Micro-B 5Gbps
Board Level Trigger Connector	8-pin Molex 1.25 mm pitch
Enclosed Trigger Connector	Hirose round 8-pin
Trigger	Software and hardware
Board Level Trigger Input	1 input, 3.3v (with internal pullup resistor)
Enclosed Trigger Input	1 optically isolated, 5-12V DC at 4-11 mA
Board Level GPO/Strobe	2 outputs, 3.3V
Enclosed GPO/Strobe	2 outputs, 3.3V & 1 optically isolated max
GPI	1 input, 3.3v (with internal pullup resistor)

MECHANICALS	
Dimensions (mm)	55 x 38.5 x 30.29
Weight (g)	35.8 (board level without optics)
Mounting	C-Mount

POWER REQUIREMENTS	
Voltage Required	5V DC (from USB connector)

BOARD LEVEL GPIO INTERFACE PIN NAME & DESCRIPTION	
1	3.3V power output
2	TRIGGER/GPI 3.3V HCMOS input
3	Ground
4	GPO1, 3.3V HCMOS output
5	GPO2, 3.3V HCMOS output
6	Clock, 3.3V (I2C access for OEMs)
7	Data, 3.3V (I2C access for OEMs)
8	No Connection
Board connector: Molex (8-pin, 1.25mm pitch, vertical)	
Cable receptacle: Molex 51021-0800;	
Cable crimp terminals: Molex 50079-8100	

ENCLOSED GPIO INTERFACE PIN NAME & DESCRIPTION	
1	VBUS (Power output from USB3 cable)
2	TRIGGER + (optically isolated)
3	TRIGGER - (optically isolated)
4	GPO1 + (optically isolated)
5	GPO1 - (optically isolated)
6	GPO1, 3.3V HCMOS output (I2C- SCL for autofocus)
7	GPO2, 3.3V HCMOS output (I2C- SDA for autofocus)
8	Ground (logic and chassis ground)

ENVIRONMENTAL & REGULATORY	
Compliance	FCC, CE & RoHS
Operating Temperature	0°C to 50°C
Storage Temperature	-45°C to 85°C

SOFTWARE	
Pixelink Capture	Control & operate multi-camera
Pixelink SDK	Software Development Kit
Pixelink μ Scope	Acquisition, analysis & reporting
3rd. Party U3V Vision Applications	

COMPUTER & OPERATING SYSTEM (minimum requirements)				
	Windows	Linux x86	Linux ArmV7	Linux ArmV8
Processor	Intel i5	Intel i5	Arm 7 (32 bit)	Arm8 (64 bit)
Memory	4GB recommended	4GB recommended	2GB	2GB
Hard Drive	150 MB	150 MB	50 MB	50 MB
Operating System	Windows 7/8/10	Ubuntu 14.04 16.04	Ubuntu 14.04 16.04	Ubuntu 14.04 16.04

Mechanical Drawing

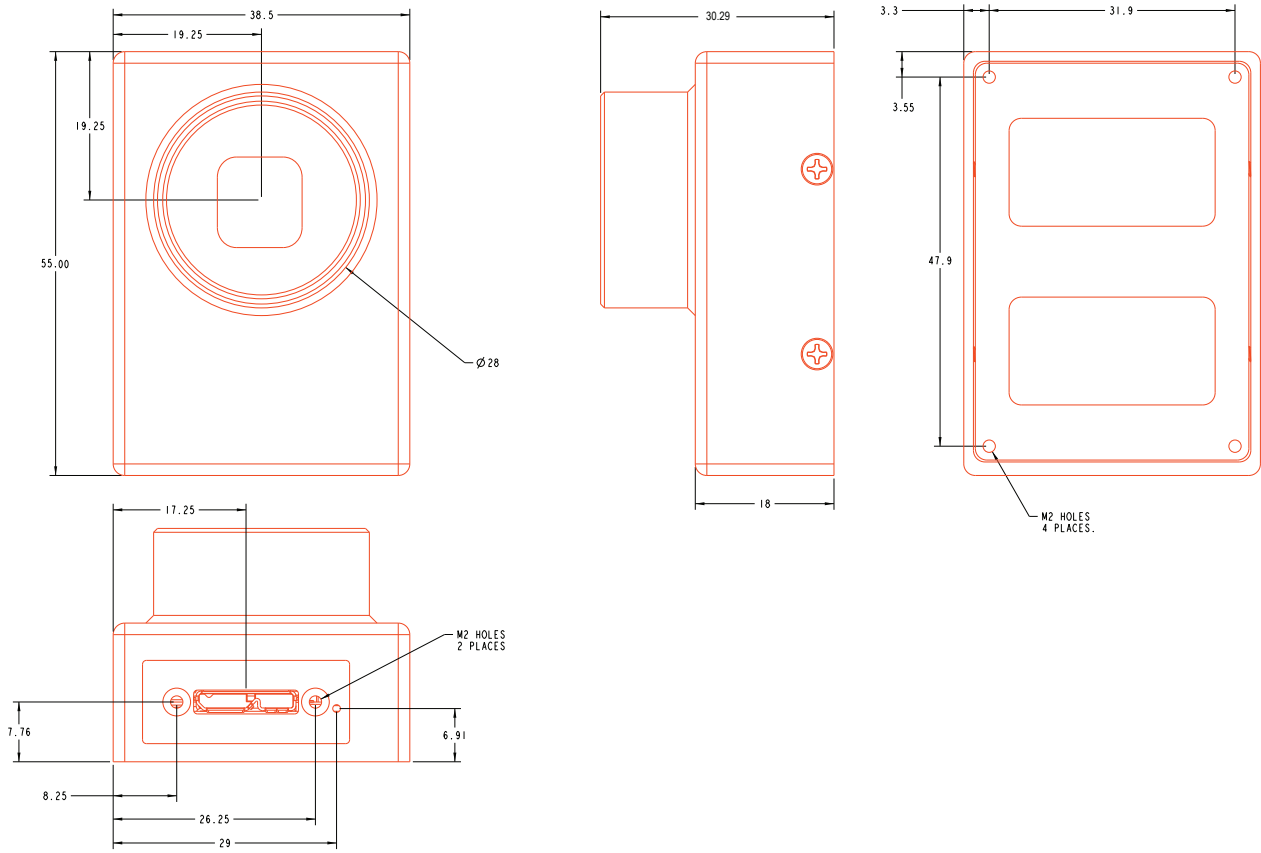

RESPONSIVITY CURVE - COLOR

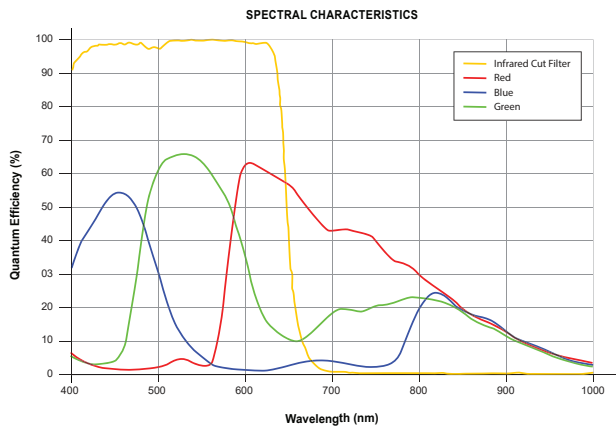

RESPONSIVITY CURVE - MONO

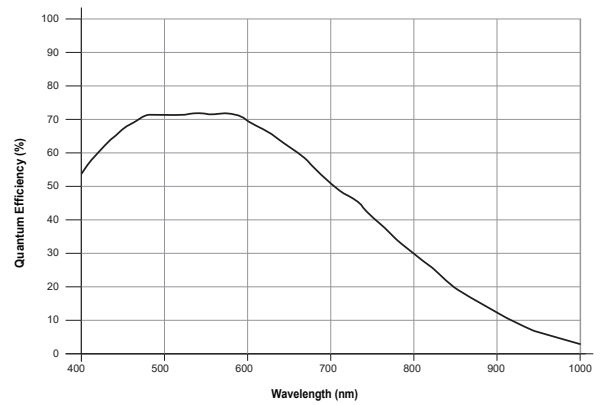

PIXELINK CAPTURE

Pixelink Capture is powerful multi-camera software application designed to configure “n” number of cameras and stream “n” number of cameras simultaneously in real-time high-quality video viewed in a multi-window environment. It offers options for complex image enhancements such as exposure control and filtering, in addition to multi-camera application testing and configuration.

Pixelink Capture features allow you to measure supporting point, line, circle, rectangle, polyline and polygon measurements while determining pixel location. The user can review and adjust data before exporting the findings to an Excel spreadsheet for further analysis.

Pixelink Capture also has integrated lens control (zoom & focus) for Navitar motorized lenses and accurate autofocus options for Navitar motorized fine focus mechanisms.

PIXELINK SDK

Providing full control of all camera functions, the Pixelink Software Development Kit (SDK) is the software package of choice for developers and system integrators who are integrating Pixelink cameras into their applications. The Pixelink SDK provides access to the full Pixelink Application Programming Interface (API) and provides sample applications, wrappers for many 3rd party controls, such as LabVIEW, along with full documentation.

The Pixelink SDK is compatible with Microsoft Windows and popular Linux platforms. When using the Pixelink SDK, developers can integrate Pixelink cameras into their applications with ease.

AVAILABLE CONFIGURATIONS

- PL-D759CU
- PL-D759CU-BL
- PL-D759CU-T
- PL-D759MU
- PL-D759MU-BL
- PL-D759MU-T

COLOR SPACE

- C = Color
- M = Mono
- NIR = Near Infrared

INTERFACE

- F = Firewire
- G = 10 GigE
- U = USB

HOUSING

- CS = CS Mount
- S-BL = S Mount Board Level
- BL = Board Level
- T = Trigger

