

# Pixelink<sup>®</sup>

**AMETEK<sup>®</sup>**

## PL-D797

CMOS | SONY IMX428 | GLOBAL SHUTTER

The Pixelink PL-D797 camera is based on the Sony IMX428 3rd generation Pregius CMOS shutter sensor technology and is available in color monochrome versions. The Pixelink PL-D797 camera has a 7.1 megapixel resolution, 1.1" lens format, a 17.60mm sensor diagonal and dynamic range of 72 dB. This camera is the lower frame rate counterpart to existing PL-D757 model which features the Sony IMX420 sensor.

The PL-D797 camera is USB3 Vision compliant and is available in board level or enclosed configurations, with or without an external trigger. This model is the perfect product solution for customers who want a high quality camera, yet don't require the higher frame rate feature traditionally associated with Sony Pregius image sensors.

As with all Pixelink cameras, the new PL-D797 models are compatible with Pixelink Capture, a free, real-time, interactive, multi-camera software application.

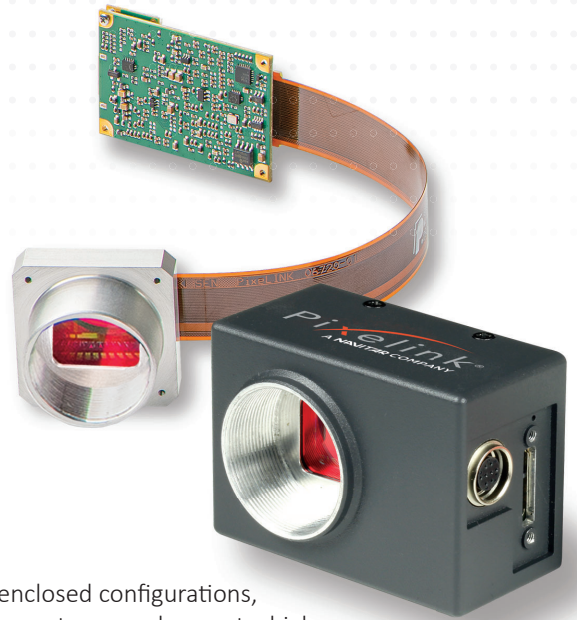

### KEY FEATURES

7.1 MP  
CMOS

51 fps

4.5  $\mu$ m

17.6 mm

SENSOR SIZE  
1.1"

12-BIT

COLOR

MONO

USB 3

US3<sup>®</sup>  
VISION

### TYPICAL APPLICATIONS

- Parts Inspection
- Strength Testing
- Metrology
- Biometrics
- Medical Imaging
- PCB & Flat Panel Display Inspection

Pixelink<sup>®</sup>  
AMETEK

1.833.247.1211 (North America)  
+1.613.247.1211 (International)

sales.pixelink@ametek.com

## SENSOR

Sensor	Sony IMX428
Type	CMOS Global Shutter
Resolution	7.1MP (3208 x 2200)
Pixel Pitch	4.5 μm x 4.5 μm
Active Area	17.6 mm diagonal

## PERFORMANCE SPECIFICATIONS

FPN	<0.03% of signal
PRNU	<0.4% of signal
Dynamic Range	72 dB
Bit Depth	8-bit or 12-bit
Color Data Formats	Bayer 8, Bayer 12 Packed, Bayer 16, YUV422, RGB24 & BGR24
Mono Data Formats	Mono 8, Mono 12 Packed & Mono 16

## FRAME RATES

Resolution	Free Running
3208 x 2200	51.4 fps
1280 x 1024	108.2 fps
640 x 480	219.7 fps

\* Frame rate will vary based on host system and configuration.  
 \*\* Above calculations based on fixed frame rate mode

## INTERFACES

Interface   Data Rate	USB 3.0   Micro-B   5Gbps
Board Level Trigger Connector	8-pin Molex 1.25 mm pitch
Enclosed Trigger Connector	Hirose round 8-pin
Trigger	Software and hardware
Board Level Trigger Input	1 input, 3.3v (with internal pullup resistor)
Enclosed Trigger Input	1 optically isolated, 5-12V DC at 4-11 mA
Board Level GPO/Strobe	2 outputs, 3.3V
Enclosed GPO/Strobe	2 outputs, 3.3V and 1 optically isolated max 40V DC, max 15mA
GPI	1 input, 3.3v (with internal pullup resistor)

## MECHANICALS

Dimensions (mm)	55 x 38.5 x 30.29
Weight (g)	35.8 (board level without optics)
Mounting	C, S-Mount

## POWER REQUIREMENTS

Voltage Required	5V DC (from USB connector)
------------------	----------------------------

## BOARD LEVEL GPIO INTERFACE PIN NAME & DESCRIPTION

1	3.3V power output
2	TRIGGER/GPI 3.3V HCMOS input
3	Ground
4	GPO1, 3.3V HCMOS output
5	GPO2, 3.3V HCMOS output
6	Clock, 3.3V (I2C access for OEMs)
7	Data, 3.3V (I2C access for OEMs)
8	No Connection

Board connector: Molex (8-pin, 1.25mm pitch, vertical)  
 Cable receptacle: Molex 51021-0800;  
 Cable crimp terminals: Molex 50079-8100

## ENCLOSED GPIO INTERFACE PIN NAME & DESCRIPTION

1	VBUS (Power output from USB3 cable)
2	TRIGGER + (optically isolated)
3	TRIGGER - (optically isolated)
4	GPO1 + (optically isolated)
5	GPO1 - (optically isolated)
6	GPO1, 3.3V HCMOS output (I2C- SCL for autofocus)
7	GPO2, 3.3V HCMOS output (I2C- SDA for autofocus)
8	Ground (logic and chassis ground)

## ENVIRONMENTAL & REGULATORY

Compliance	FCC, CE & RoHS
Operating Temperature	0°C to 50°C
Storage Temperature	-45°C to 85°C

## SOFTWARE

Pixelink Capture	Control & operate multi-camera
Pixelink SDK	Software Development Kit
Pixelink μScope	Acquisition, analysis & reporting
3rd. Party U3V Vision Applications	

## COMPUTER & OPERATING SYSTEM (minimum requirements)

	Windows	Linux x86	Linux ArmV7	Linux ArmV8
Processor	Intel i5	Intel i5	Arm 7 (32 bit)	Arm8 (64 bit)
Memory	4GB recommended	4GB recommended	2GB	2GB
Hard Drive	150 MB	150 MB	50 MB	50 MB
Operating System	Windows 7/8/10	Ubuntu 16.04 18.04 20.04	Ubuntu 16.04 18.04	Ubuntu 16.04 18.04

## Mechanical Drawing

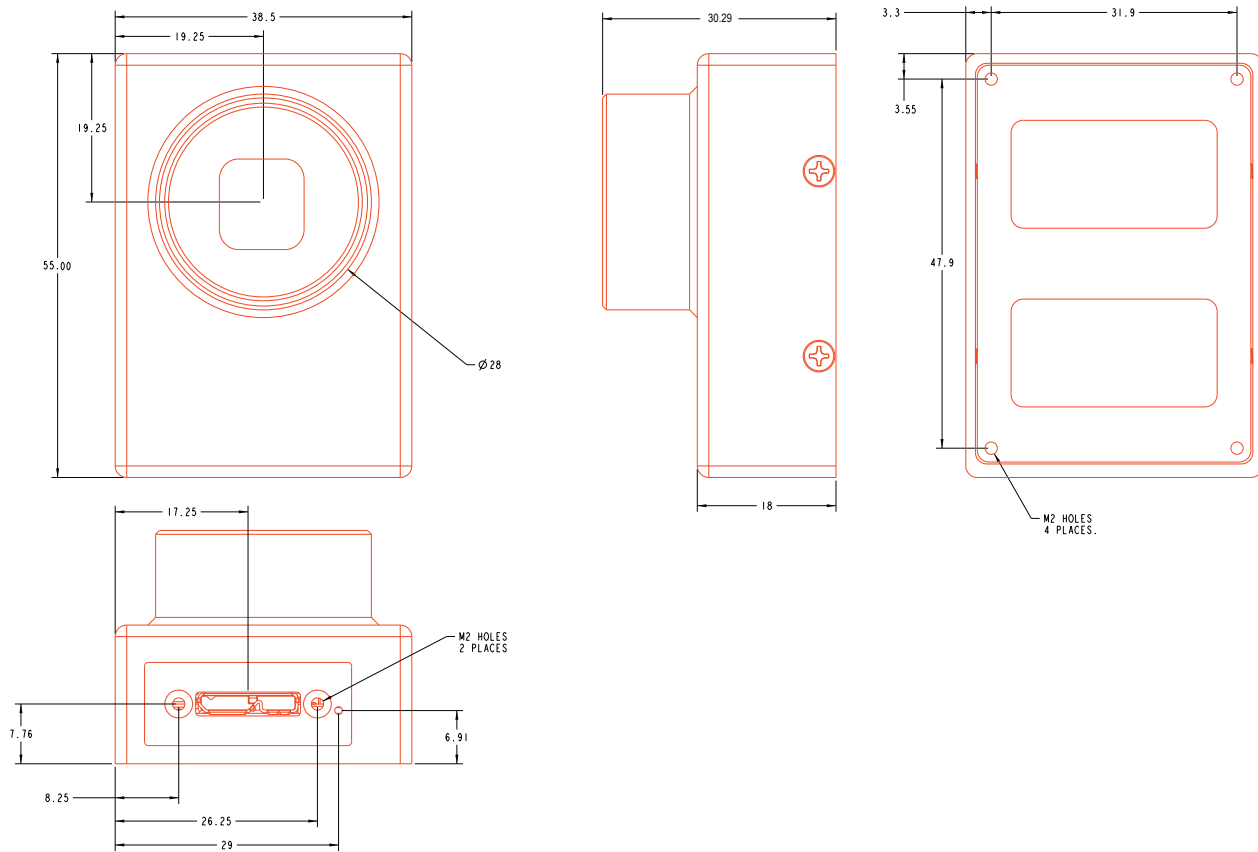

## Responsivity Curve - Color

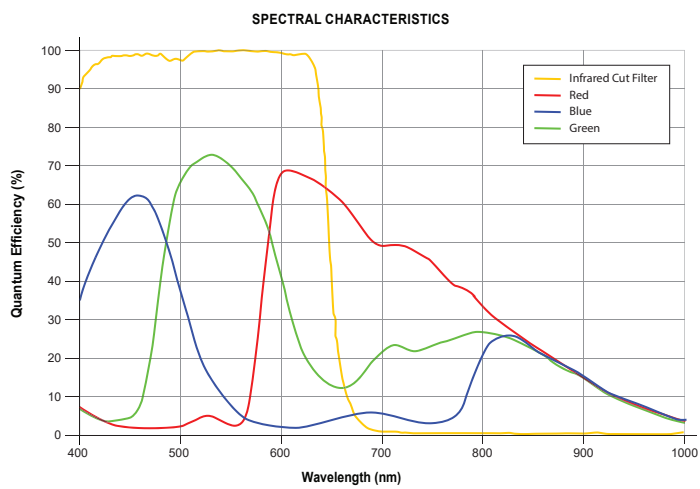

## Responsivity Curve - Mono

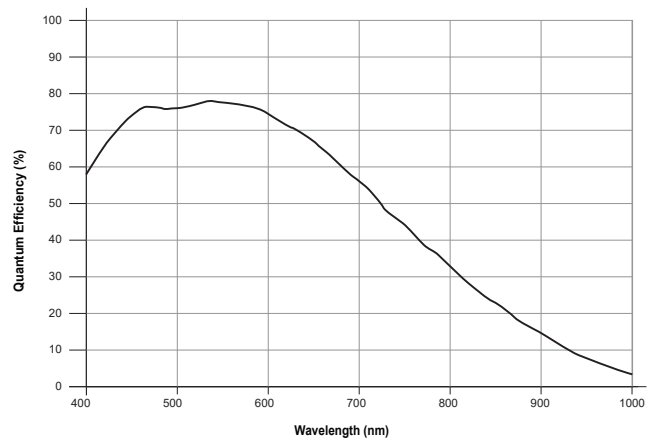

**PIXELINK CAPTURE**

Pixelink Capture is powerful multi-camera software application designed to configure “n” number of cameras and stream “n” number of cameras simultaneously in real-time high-quality video viewed in a multi-window environment. It offers options for complex image enhancements such as exposure control and filtering, in addition to multi-camera application testing and configuration.

Pixelink Capture features allows you to measure supporting point, line, circle, rectangle, polyline and polygon measurements while determining pixel location. The user can review and adjust data before exporting the findings to an Excel spreadsheet for further analysis.

Pixelink Capture also has integrated lens control (zoom & focus) for Navitar motorized lenses and accurate autofocus options for Navitar motorized fine focus mechanisms.

**PIXELINK SDK**

Providing full control of all camera functions, the Pixelink Software Development Kit (SDK) is the software package of choice for developers and system integrators who are integrating Pixelink cameras into their applications. The Pixelink SDK provides access to the full Pixelink Application Programming Interface (API) and provides sample applications, wrappers for many 3rd party controls, such as LabVIEW, along with full documentation.

The Pixelink SDK is compatible with Microsoft Windows and popular Linux platforms. When using the Pixelink SDK, developers can integrate Pixelink cameras into their applications with ease.

**AVAILABLE CONFIGURATIONS**

- PL-D797CU
- PL-D797CU-BL
- PL-D797CU-T
- PL-D797MU
- PL-D797MU-BL
- PL-D797MU-T

**COLOR SPACE**

- C = Color
- M = Mono
- NIR = Near Infrared

**INTERFACE**

- F = Firewire
- G = 10 GigE
- U = USB

**HOUSING**

- CS = CS Mount
- S-BL = S-Mount Board Level
- BL = Board Level
- T = Trigger

