

Accelerate Efficiency, Optimize Precision_

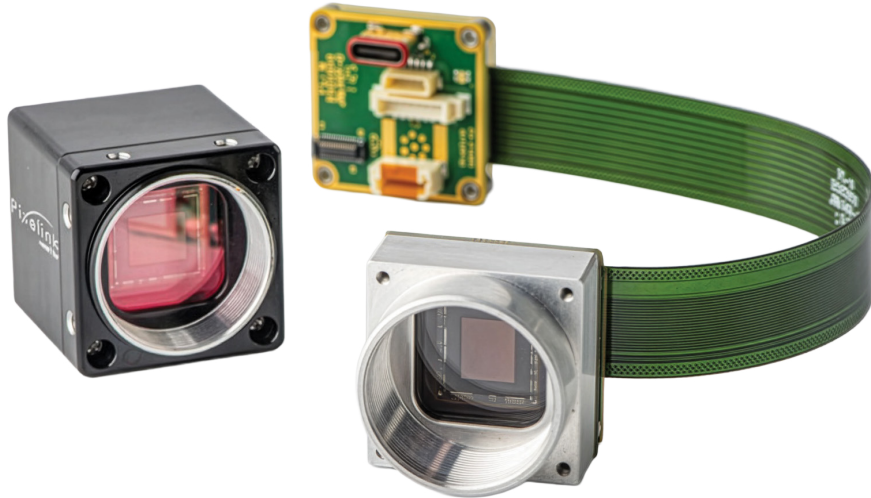

PL-U795B

PL-U Series Industrial Cameras

High-Speed Imaging Meets Seamless Integration

The PL-U family of cameras combines the exceptional performance of high frame rate CMOS sensors with the blazing data throughput of USB 3.1 Gen 1 technology—delivering outstanding value for a wide range of industrial applications.

Key Features:

- **Compact Power & Design Efficiency**
Engineered for space-conscious setups, the PL-U cameras offer powerful imaging capabilities in a compact form factor—perfect for embedded systems and tight enclosures.
- **Mechanical Design Optimization**
Built with industrial reliability in mind, the PL-U series features robust mechanical construction that ensures long-term durability and consistent performance in demanding conditions.
- **USB Type C for Seamless Integration**
Thoughtfully designed USB 3.1 Gen 1 Type-C connector placement simplifies cable management and system integration, reducing setup time and improving workflow efficiency.

AT-A-GLANCE

Product_
PL-U795B

Resolution_
5.0 MP

Sensor_
Sony IMX547

Sensor Size_
1/1.8"

Pixel Size_
2.74 μm

Markets_

- Life Sciences
- Advanced Research
- Machine Vision

Technical Specifications__

Sensor	
Sensor	Sony IMX547
Sensor Size	1/1.8"
Type	CMOS Global Shutter
Resolution	5.01 MP (2448 x 2048)
Pixel Pitch	2.74 μm x 2.74 μm
Active Area	8.8 mm diagonal

Performance Specifications	
FPN	<0.03% of signal
PRNU	<0.4% of signal
Dynamic Range	70 dB
Bit Depth	8-bit or 12-bit
Color Data Formats	Bayer 8, Bayer 12 Packed, Bayer 16, YUV422, RGB24 & BGR24
Mono Data Formats	Mono 8, Mono 12 Packed & Mono 16

Frame Rates	
Resolution	Free Running
2448 x 2048	75.5 fps
1280 x 1024	141.9 fps
640 x 480	266.9 fps

*Frame rate will vary based on host system and configuration

Interfaces	
Interface Data Rate	USB 3.1 Gen 1 USB-C 5Gbps
Board Level Trigger Connector	Molex (8-pin 1.25 mm pitch) & JST (8-pin 1.00mm pitch)
Enclosed Trigger Connector	Hirose round 8-pin
Trigger	Software and Hardware
Board Level Trigger Input	1 input, 3.3V & 1 optically isolated, 5-12V DC at 4-11 mA
Enclosed Trigger Input	1 optically isolated, 5-12V DC at 4-11 mA
Board Level GPO / Strobe	3 outputs, 3.3V and 1 optically isolated
Enclosed GPO / Strobe	3 outputs, 3.3V and 1 optically isolated
GPI	1 input, 3.3v (with internal pullup resistor)

Mechanicals	
Dimensions (mm)	31.5 x 31.5 x 46.35
Weight (g)	70g
Mounting	C-Mount

Board Level GPIO Interface Description (Molex)	
1	3.3V power output
2	HCMOS trigger input
3	Ground
4	GPO1 (Legacy / Custom)
5	GPO2 (Legacy / Custom)
6	Clock, 3.3V (I2C access for OEMs)
7	Data, 3.3V (I2C access for OEMs)
8	GPI+ (optically isolated)
Board connector: Molex (8-pin, 1.25mm pitch, vertical) Cable receptacle: Molex 51021-0800 Cable crimp terminals: Molex 50079-8100	

Board Level GPIO Interface Description (JST)	
1	3.3V or 5.0V power output
2	Trigger+ (optically isolated) or GPI +(optically isolated)
3	Trigger- (optically isolated) or GPIO1- (optically isolated)
4	GPO1+ (optically isolated)
5	GPIO2
6	GPIO3
7	GPIO4
8	Ground
Board connector: JST (8-pin 1.00mm pitch, vertical) Cable receptacle: JST NSHR-08V-S	

Enclosed GPIO Interface Description	
1	3.3V or 5.0V power output
2	Trigger+ (optically isolated) or GPI +(optically isolated)
3	Trigger- (optically isolated) or GPIO1- (optically isolated)
4	GPO1+ (optically isolated)
5	GPIO2
6	GPIO3
7	GPIO4
8	Ground

Software	
Pixelink Capture	Multi-camera control & operation
Pixelink SDK	Software Development Kit
Pixelink uScope	Acquisition, analysis & reporting

Environmental & Regulatory Information

Compliance	FCC, CE & RoHS
Operating Temperature	0° to 50° C
Storage Temperature	-45° to 85° C

Power Requirements

Voltage Required	5V DC (From USB connector)
------------------	----------------------------

Computer & Operating System (Minimum Requirements)

	Windows	Linux x86	Linux ArmV8
Processor	Intel i5	Intel i5	Arm8 (64-bit)
Memory	4GB Recommended	4GB Recommended	2GB
Hard Drive	300 MB	150 MB	50 MB
Operating System	Windows 8/10/11	Ubuntu 18.04 20.04 22.04 24.04	Ubuntu 18.04 20.04 22.04 24.04

Mechanicals__

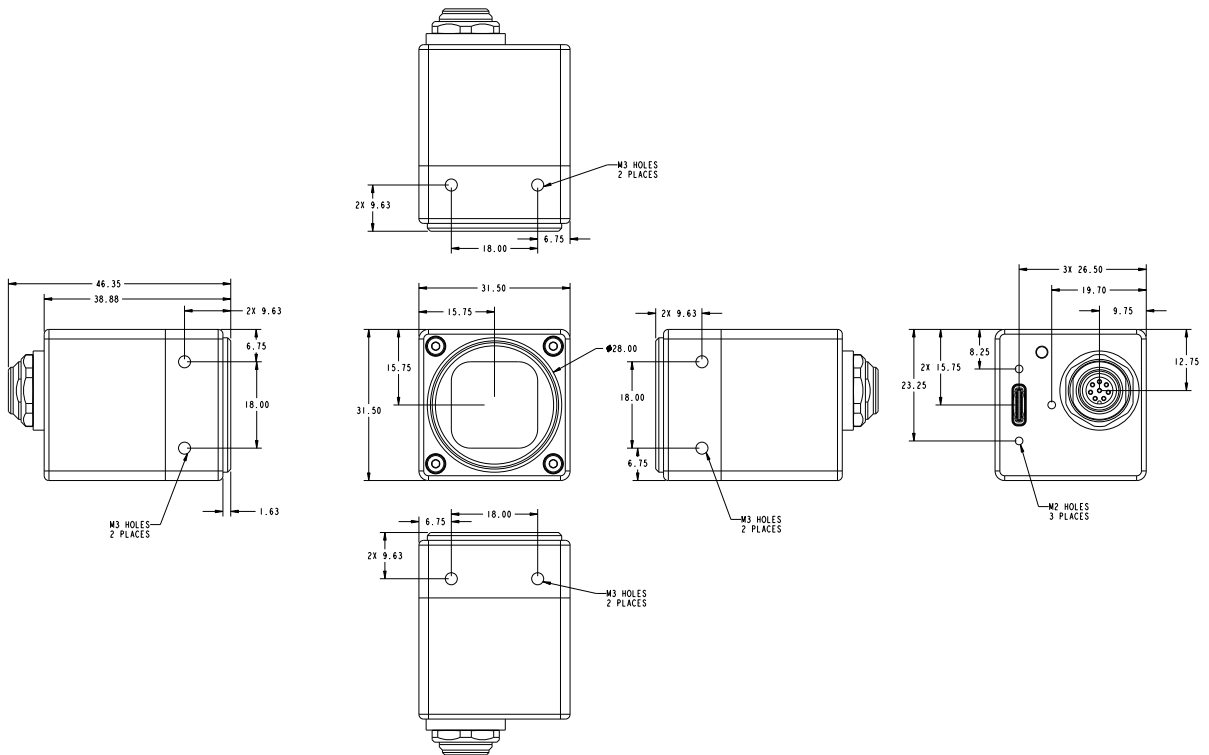

Quantum Efficiency Curves__

Colour QE

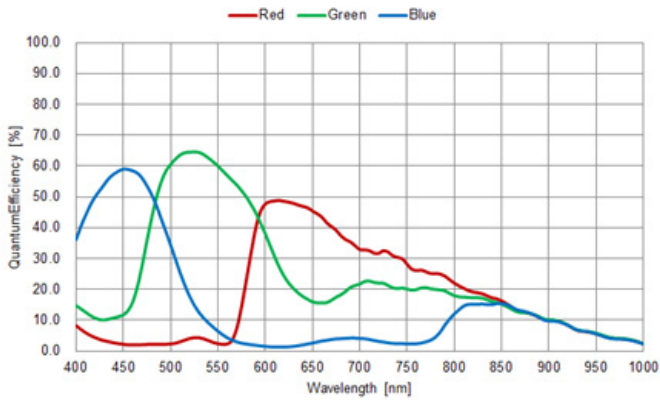

Mono QE

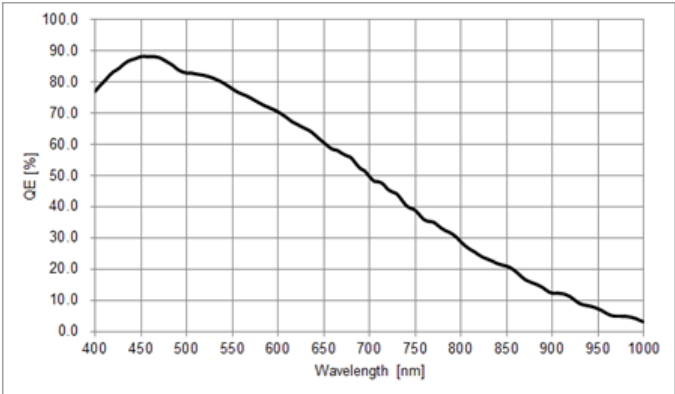

Pixelink Capture

Pixelink Capture is a robust image preview and acquisition software included with all Pixelink cameras. With an intuitive GUI, users can control up to 4 cameras at once and effortlessly adjust key imaging parameters such as region of interest (ROI), exposure, gain, frame rate, and color—all before capturing still images or video clips.

Key features include

- High-quality image and video capture
- Real-time video streaming
- Full control of trigger and GPIO settings
- Resizable region of interest (ROI)
- Customizable multi-camera views
- Integrated zoom and focus controls
- Autofocus support for Navitar, Corning Varioptic, Optotune and Edmund lenses

Pixelink SDK

The Pixelink Software Development Kit (SDK) delivers comprehensive control over all camera functions, making it the preferred choice for developers and system integrators. Designed for ease of use, the SDK facilitates seamless integration of Pixelink cameras into custom Windows and Linux applications.

Key features include:

- Fast and Easy Integration
- Multi-Language Support
- Cross-Platform Compatibility
- Third-Party Software Compatibility
- Embedded System Support
- Sample Applications
- Consistent API, Maintaining Backwards Compatibility
- Free Technical Support

Available Configuration

- PL-U795BMU-T
- PL-U795BMU-BL
- PL-U795CU-T
- PL-U795CU-BL

Color Space

- C = Color
- M = Mono

Housing

- BL = Board level
- T = Trigger

Interface

- U = USB 3.1 Gen 1 (Type -C)



1000 Innovation Drive, Suite
100 Ottawa, ON K2K 3E7
Canada
+1 613.247.1211
sales.pixelink@ametek.com
navitar.com/pixelink

Your favorite engineers' favorite engineers__

